

ASCIUGAMANI ELETTRICI



LFHD1E - BIANCO





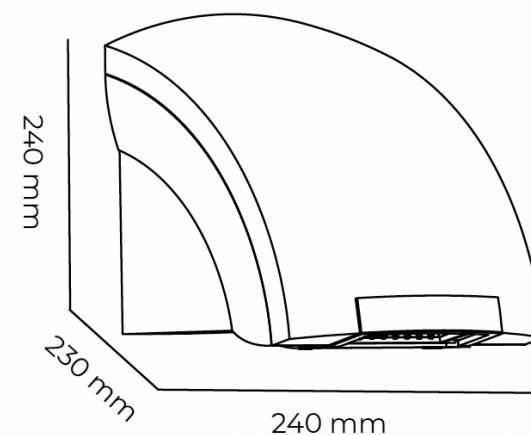

LFHD3E - SILVER

ASCIUGAMANI ELETTRICO ROCKET

INSTALLAZIONE: A PARETE
AZIONAMENTO: CON SENSORE
MATERIALE COPERCHIO: ABS
TENSIONE: 220V/240V
FREQUENZA: 50/60 HZ
RESISTENZA ELETTRICA: 1000 W
ASSORBIMENTO TOTALE: 1800 W
GRADO DI PROTEZIONE INTERNA: IPX1
GRADO DI PROTEZIONE ELETTRICA: CLASSE II
VELOCITÀ USCITA ARIA: 58 KM/H
PORTATA ARIA: 250 M3 /H
RUMOROSITÀ: 60 DB
DIMENSIONI: H 240 X L 240 X P 230 mm
PESO: 2,4 KG
MARCHI DI QUALITÀ: CE - ROHS
GARANZIA: 2 ANNI



 COD.			
LFHD1E	1800 W	62,53	1/8
LFHD3E	1800 W	75,02	1/8